

SPLIT TYPE
AIR CONDITIONER
DUCT TYPE (50Hz)

SERVICE MANUAL



Indoor unit Outdoor unit
ARYG45LMLA AOYG45LETL

CONTENTS

SPECIFICATIONS.....	1
DIMENSIONS.....	2
REFRIGERANT SYSTEM DIAGRAM... ..	3
CIRCUIT DIAGRAM.....	4
INDOOR PCB CIRCUIT DIAGRAM.....	5
OUTDOOR PCB CIRCUIT DIAGRAM... ..	8
ERROR DETECTION.....	14
PARTS (INDOOR UNIT).....	18
PARTS (OUTDOOR UNIT).....	21
ACCESSORIES.....	24

SPECIFICATIONS

ELECTRICAL DATA

TYPE	Cooling & Heating	
INDOOR UNIT	ARYG45LMLA	
OUTDOOR UNIT	AOYG45LETL	
COOLING CAPACITY	12.1 kW	
HEATING CAPACITY	13.3 kW	
POWER SOURCE	230 V, 50 Hz, single phase	
RUNNING CURRENT	Cooling	16.5 A
	Heating	16.1 A
INPUT WATTS	Cooling	3.77 kW
	Heating	3.68 kW
E.E.R.	Cooling	3.21 kW/kW
C.O.P.	Heating	3.61 kW/kW
MOISTURE REMOVAL	4.0 L/hr	
AIR CIRCULATION INDOOR	2,100 m ³ /h	
AIR CIRCULATION OUTDOOR	Cooling	6,750 m ³ /h
	Heating	6,200 m ³ /h
MAXIMUM CURRENT	21.0 A	

FAN MOTOR

INDOOR UNIT, Discrimination	MFG-45RVN	
INDOOR UNIT	High	1,350 r.p.m.
	Medium	1,150 r.p.m.
	Low	910 r.p.m.
	Quiet	770 r.p.m.
OUTDOOR UNIT, Discrimination	MFE-45VVT	
OUTDOOR UNIT Cooling	Upper fan	850 r.p.m.
	Lower fan	800 r.p.m.
OUTDOOR UNIT Heating	Upper fan	780 r.p.m.
	Lower fan	750 r.p.m.

NOISE LEVEL

INDOOR UNIT	High	42 dB
	Medium	38 dB
	Low	32 dB
	Quiet	28 dB
OUTDOOR UNIT	55 dB	

COMPRESSOR AND REFRIGERANT

TYPE	Hermetic type, Inverter, 6 poles, 3 phase, DC motor, Twin Rotary		
DISCRIMINATION	N-TF30HD1A		
WEIGHT (with oil)	15.4 kg		
REFRIGERANT TYPE	R410A		
PRECHARGED REFRIGERANT	3,350 g		
MAX PIPE HEIGHT	30 m		
FULL CHARGE	Pipe length	20 m	3,350 g
		30 m	3,750 g
		40 m	4,150 g
		50 m	4,550 g
ADDITIONAL CHARGE	40 g/m		

DIMENSIONS

INDOOR UNIT	H x W x D	270 x 1,135 x 700 mm
OUTDOOR UNIT	H x W x D	1,290 x 900 x 330 mm

WEIGHT

INDOOR UNIT	Shipping / Net	47 kg / 40 kg
OUTDOOR UNIT	Shipping / Net	94 kg / 86 kg

DIMENSIONS

(Unit : mm)

INDOOR UNIT

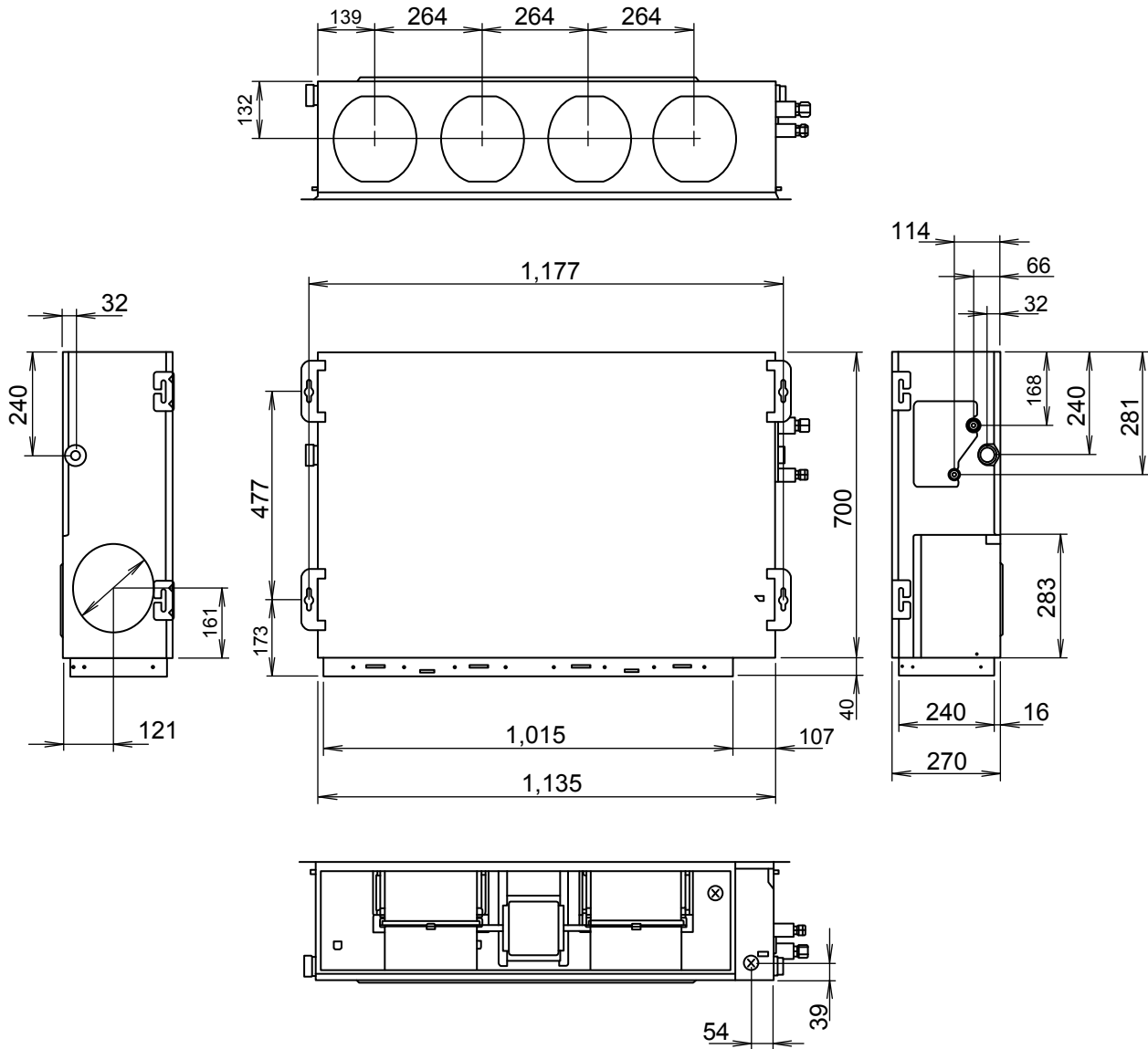

OUTDOOR UNIT

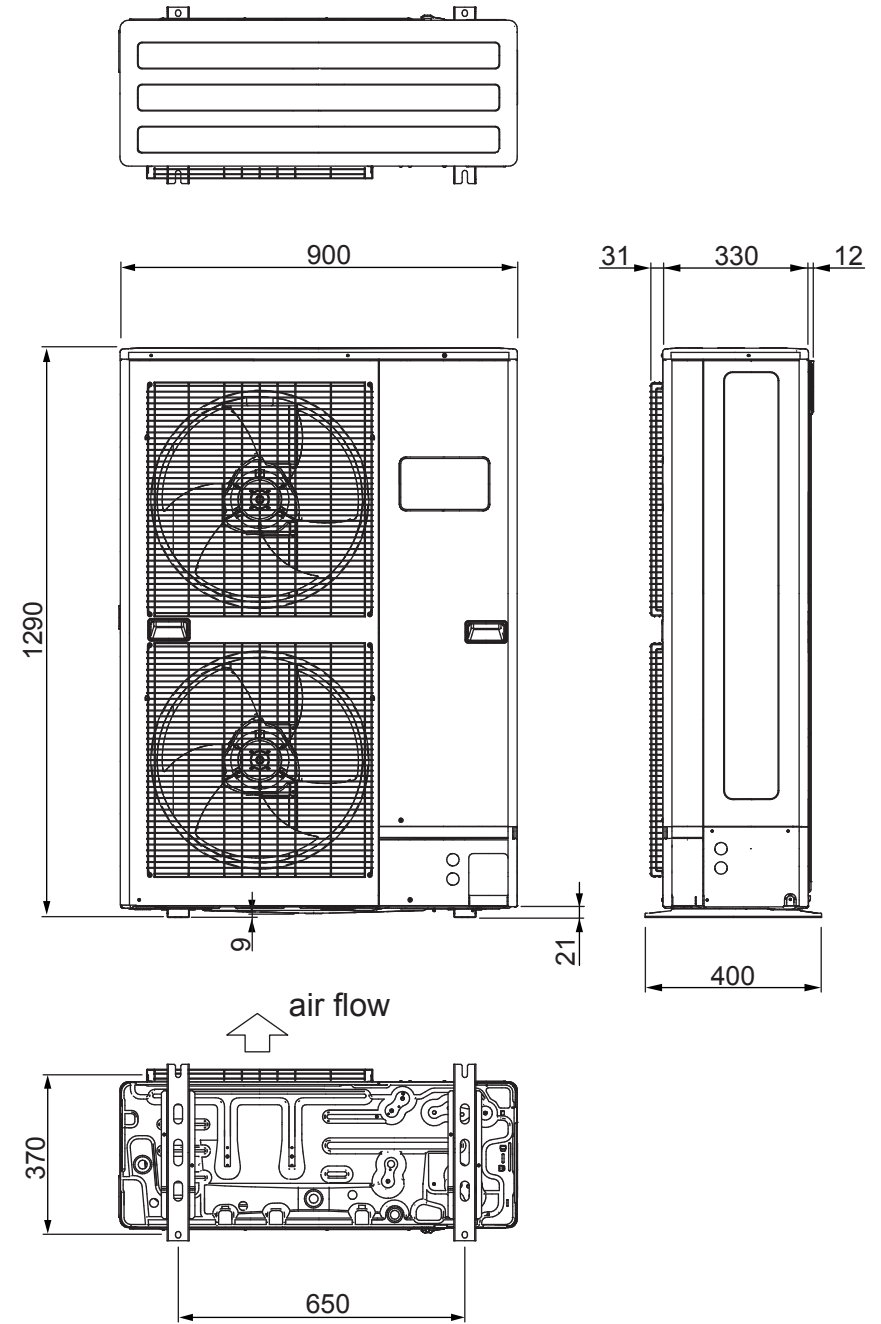

REFRIGERANT SYSTEM DIAGRAM

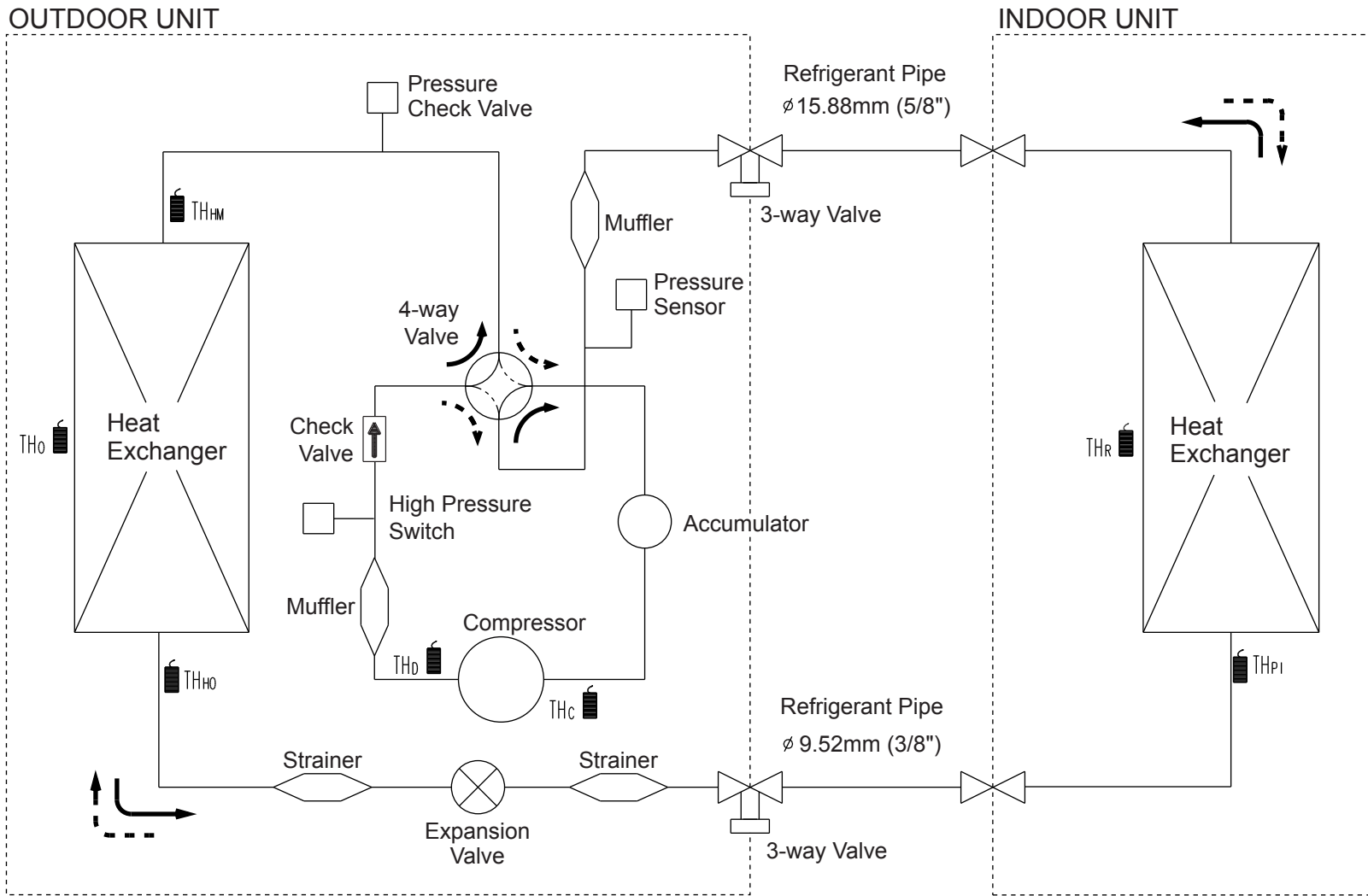

Refrigerant direction

→ Cool

---→ Heat

TH_c : Thermistor (Compressor)

TH_d : Thermistor (Discharge)

TH_{HM} : Thermistor (Heat Exchanger Med)

TH_{HO} : Thermistor (Heat Exchanger Out)

TH_o : Thermistor (Outdoor)

TH_R : Thermistor (Room)

TH_{Pi} : Thermistor (Pipe)

CIRCUIT DIAGRAM

OUTDOOR UNIT

INDICATOR PCB

MAIN PCB

INDOOR UNIT

MAIN PCB

TRANSISTOR PCB (IPM)

CAPACITOR PCB

ACTPM

CHOKE COIL

FILTER PCB

COMPRESSOR

CN101 HIGH PRESSURE SWITCH

CN61 THERMISTOR (OUTDOOR TEMP.)

THERMISTOR (PIPE TEMP.)

CN63 THERMISTOR (PIPE - MID. TEMP.)

THERMISTOR (DICHARGE TEMP.)

CN62 THERMISTOR (COMP. SHELL TEMP.)

CN91 PS

CN6 4WV 4-WAY VALVE

CN111 PMV EXPANSION VALVE

CN800 FM FAN MOTOR (UPPER)

CN802 FM FAN MOTOR (LOWER)

THERMISTOR (PIPE TEMP.)

THERMISTOR (ROOM TEMP.)

TERMINAL

TO WIRED REMOTE CONTROL

TERMINAL

POWER SUPPLY PCB

EX. IN EX. OUT (OPTION)

COIL

FAN MOTOR

FM

INDOOR PCB CIRCUIT DIAGRAM

CONTROL UNIT
EZ-01229HSE

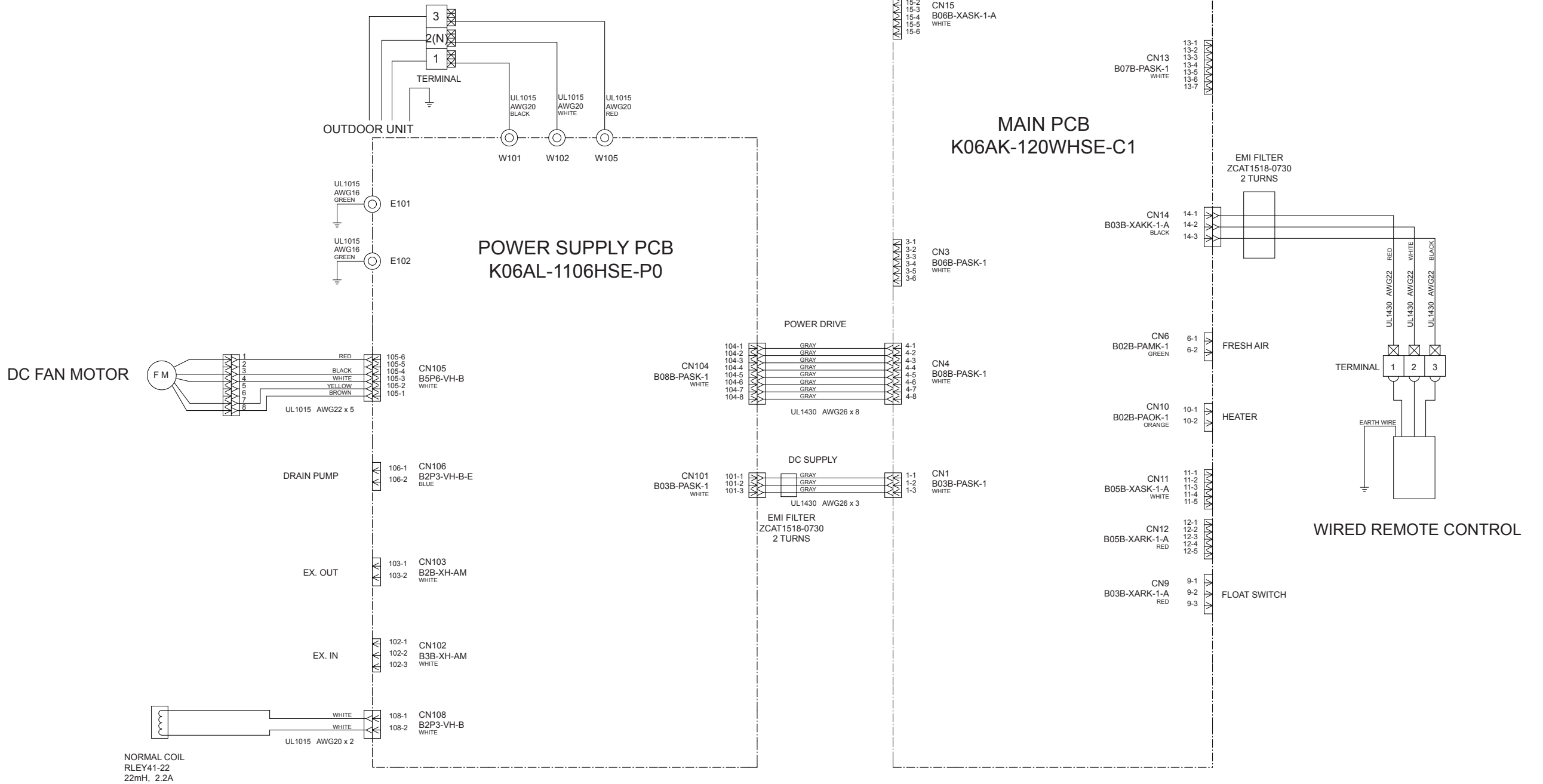

INDOOR UNIT
MAIN PCB
K06AK-120WHSE-C1

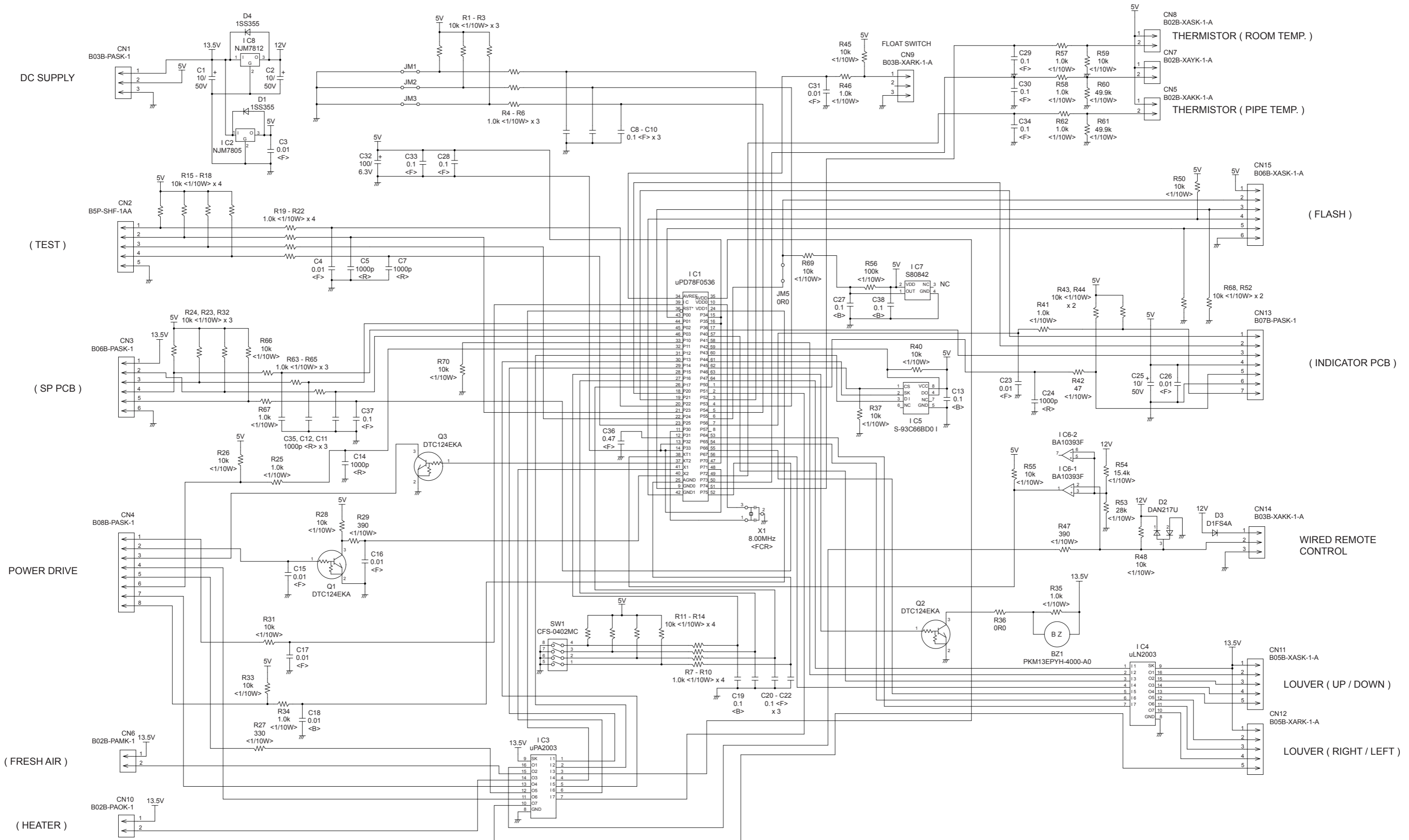

NORMAL COIL

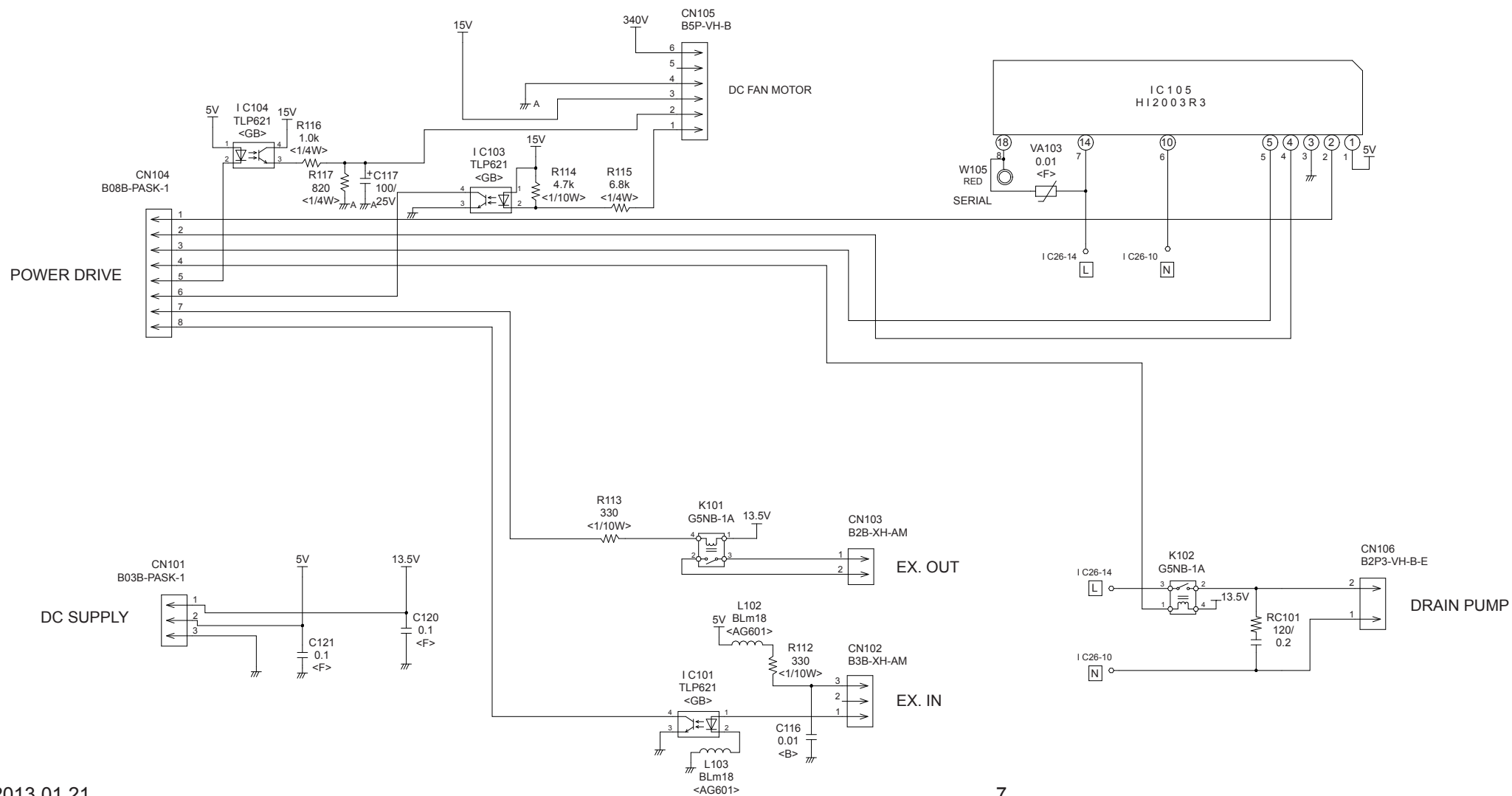
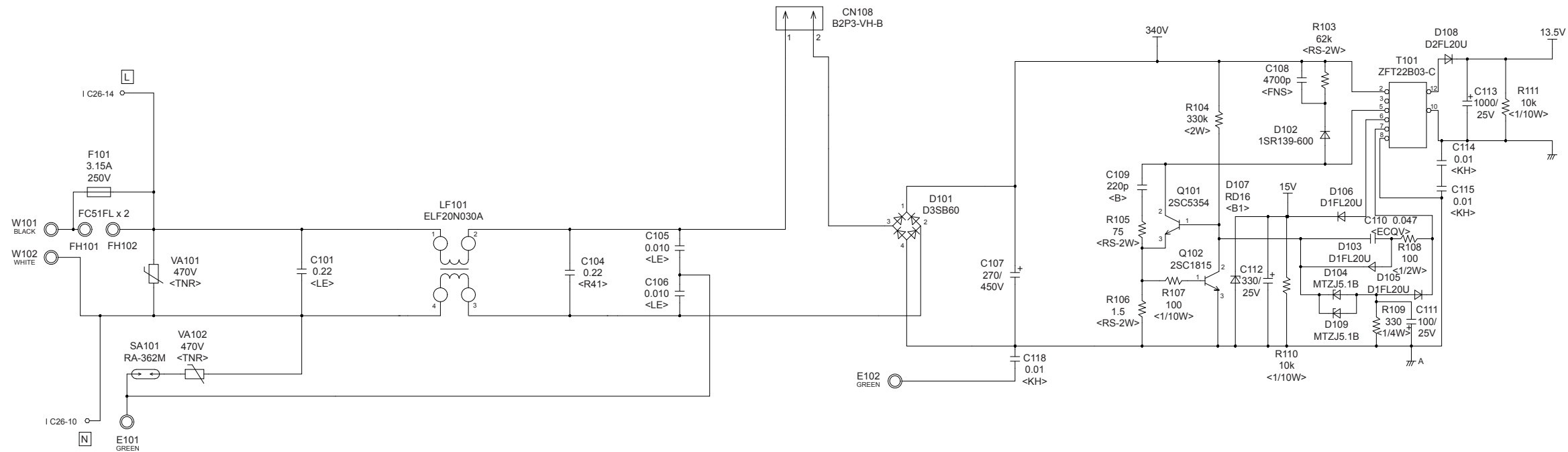

INDOOR UNIT
POWER SUPPLY PCB
K06AL-1106HSE-P0

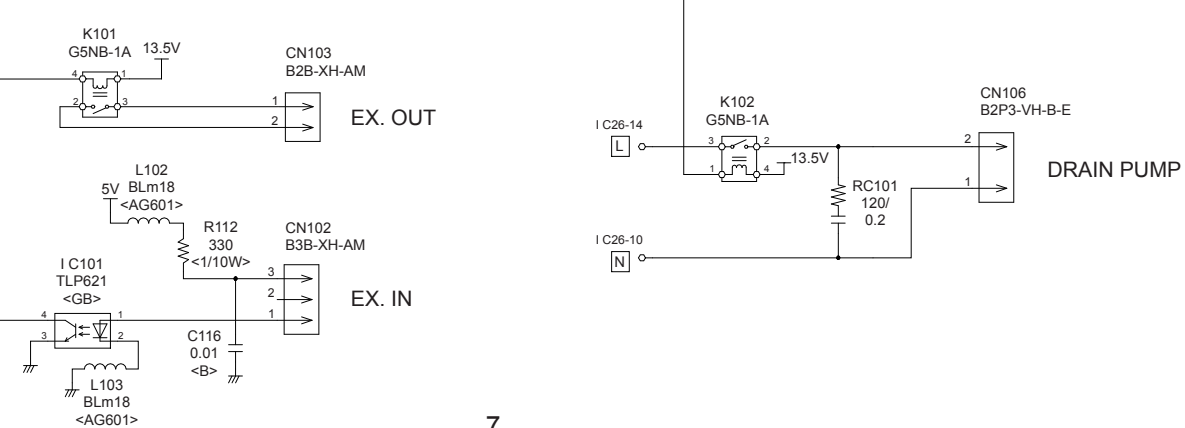

OUTDOOR PCB CIRCUIT DIAGRAM

INVERTER ASSEMBLY
EZ-0121HHUE

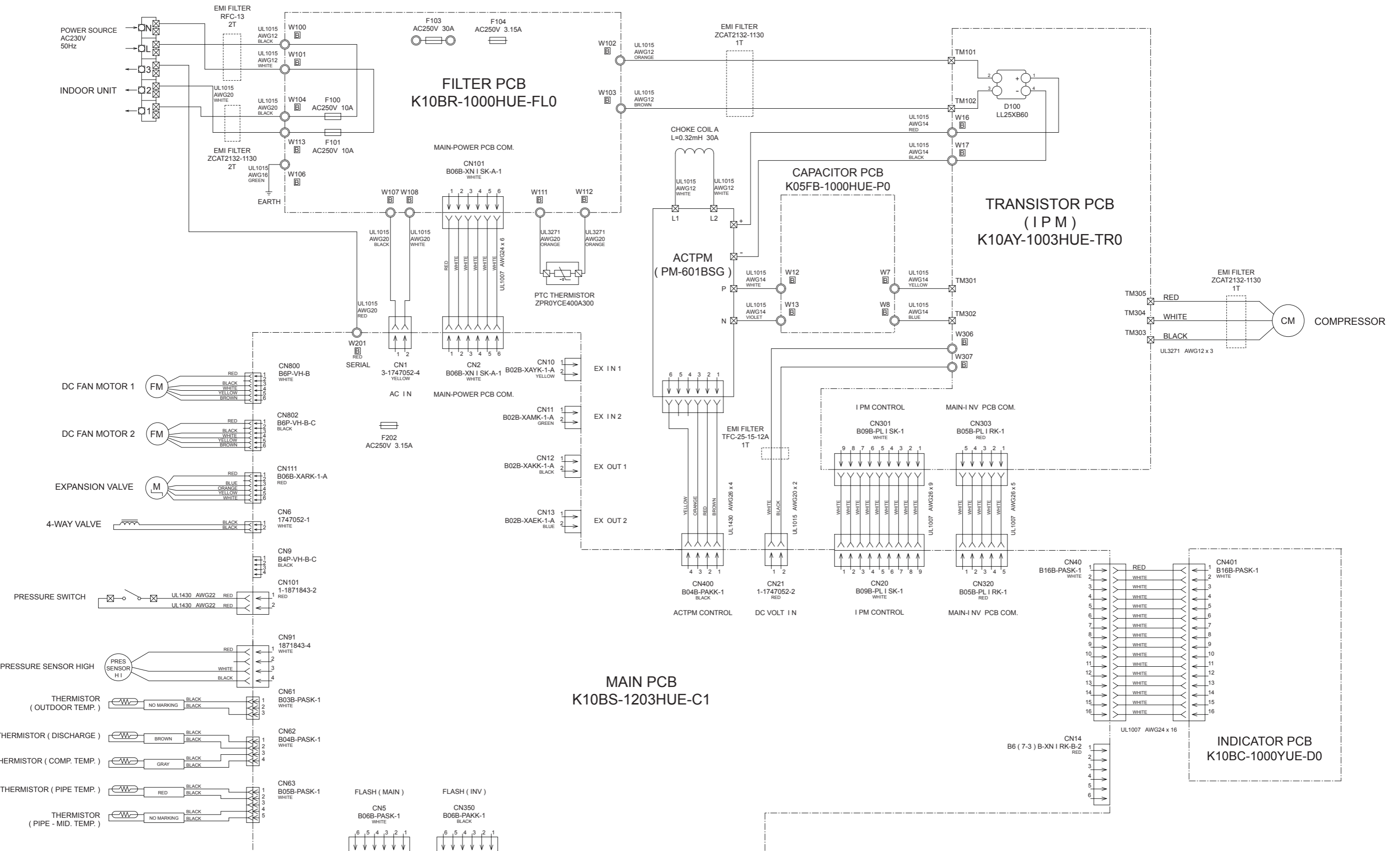

OUTDOOR UNIT
 MAIN PCB - 1
 K10BS-1203HUE-C1

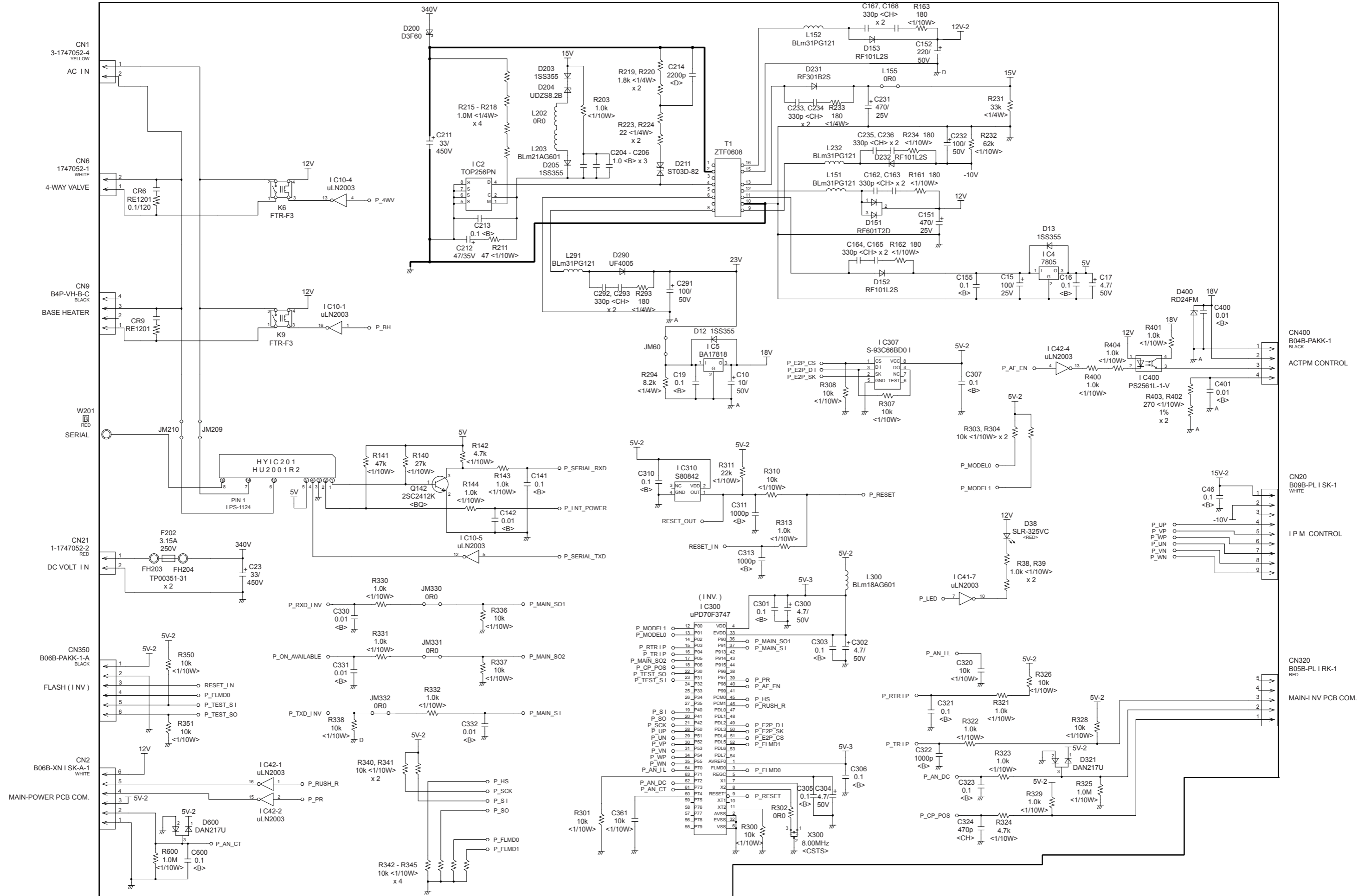

OUTDOOR UNIT
MAIN PCB - 2
K10BS-1203HUE-C1

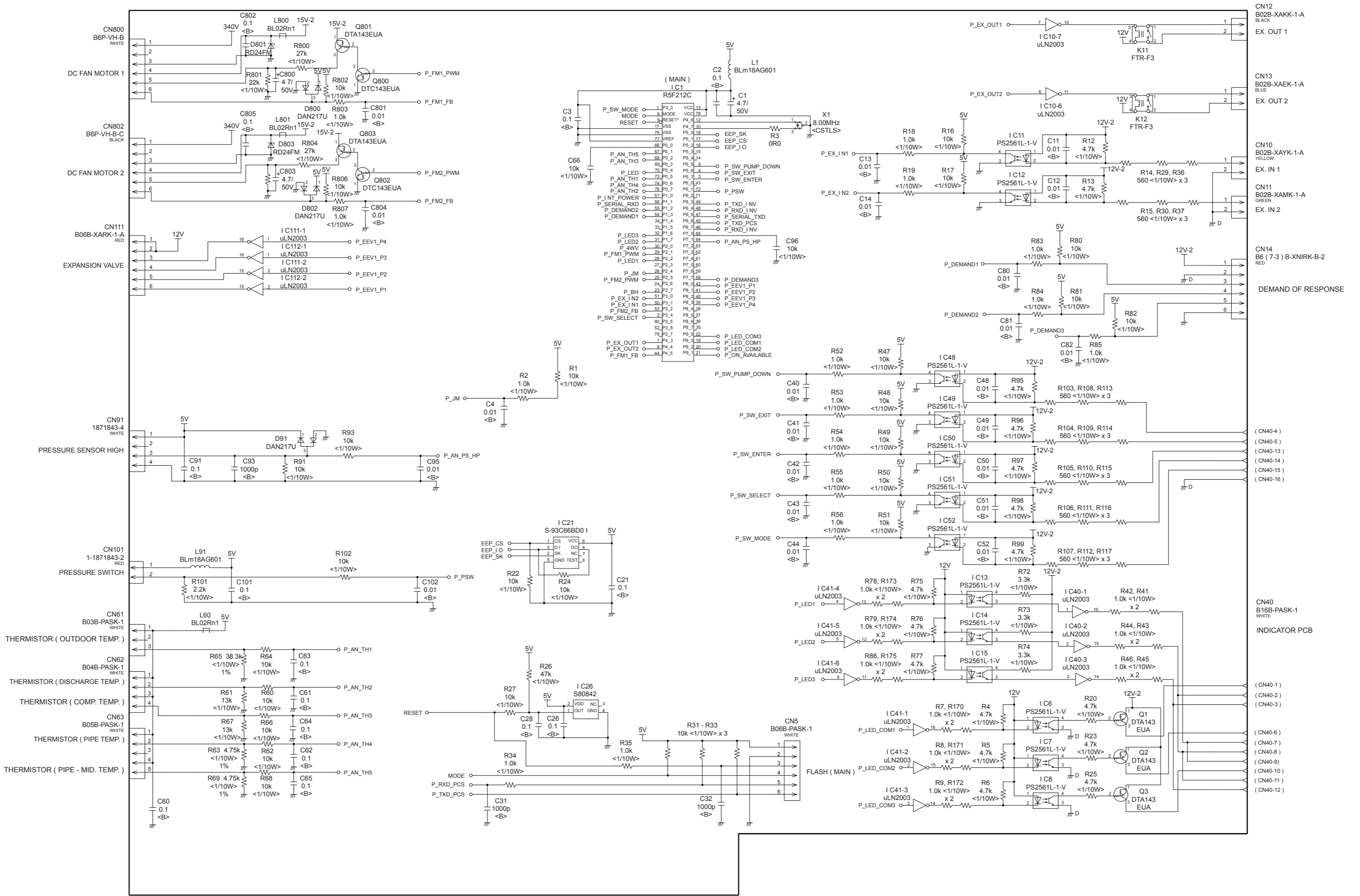

OUTDOOR UNIT TRANSISTOR PCB (I P M) K10AY-1003HUE-TR0

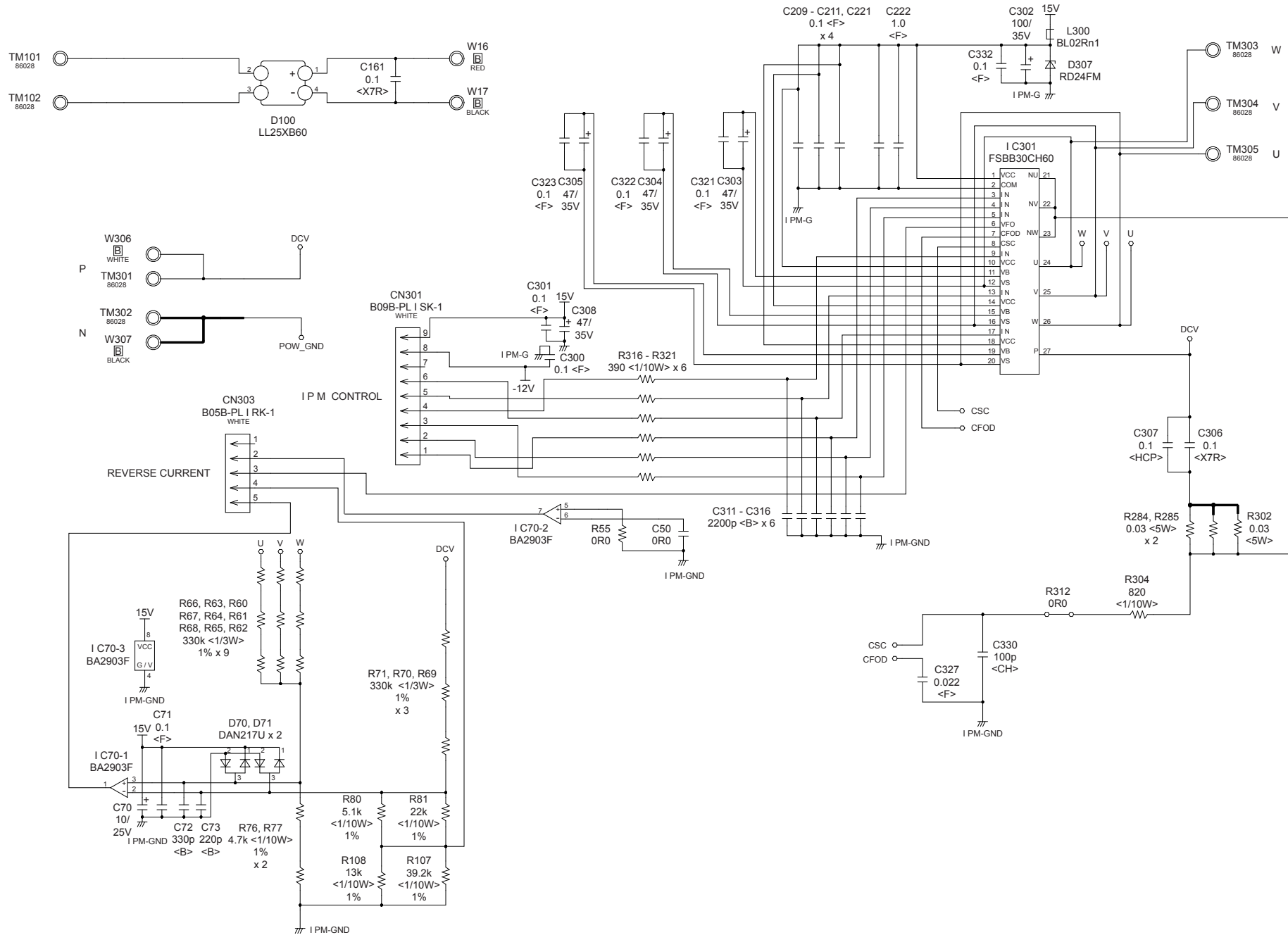

OUTDOOR UNIT POWER SUPPLY PCB K10BR-1000HUE-FL0

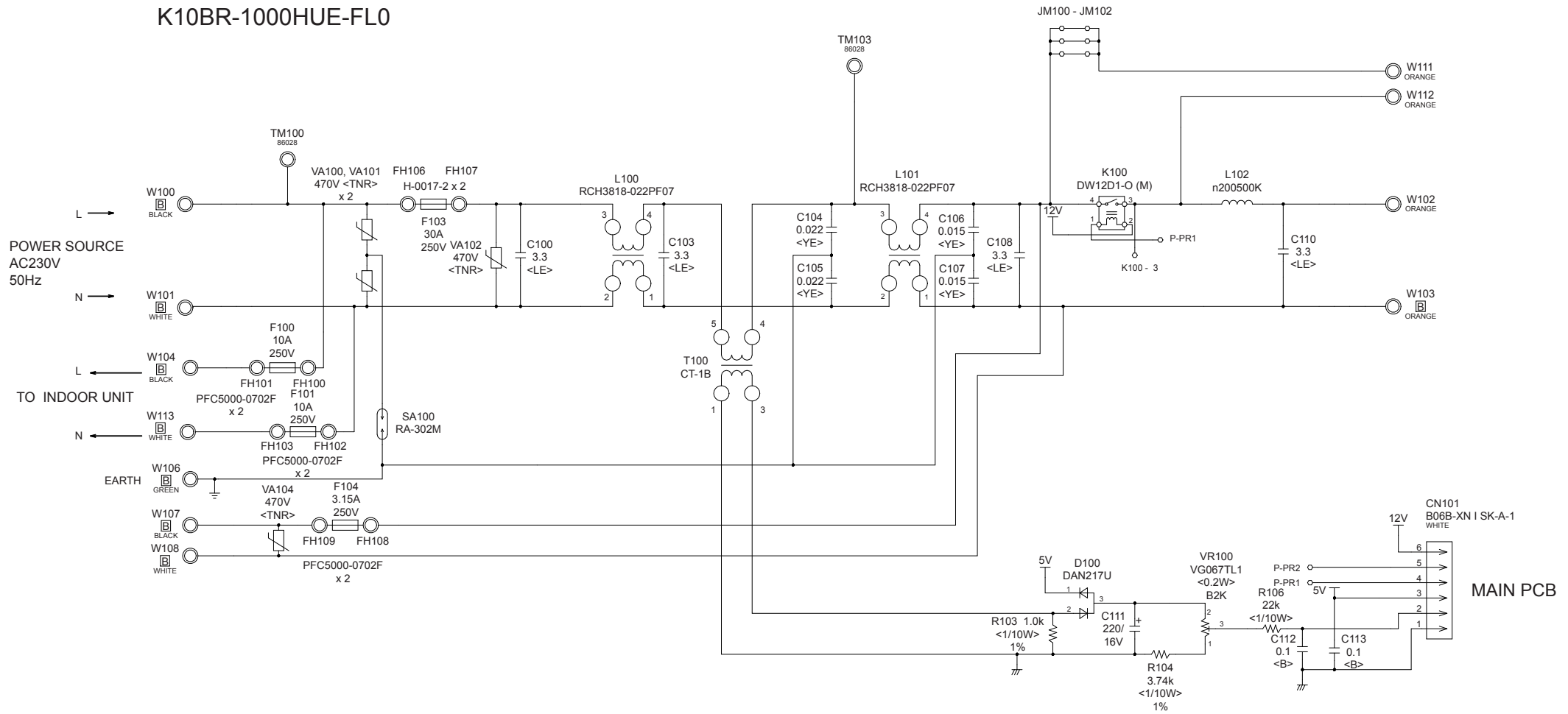

OUTDOOR UNIT
CAPACITOR PCB
K05FB-1000HUE-P0

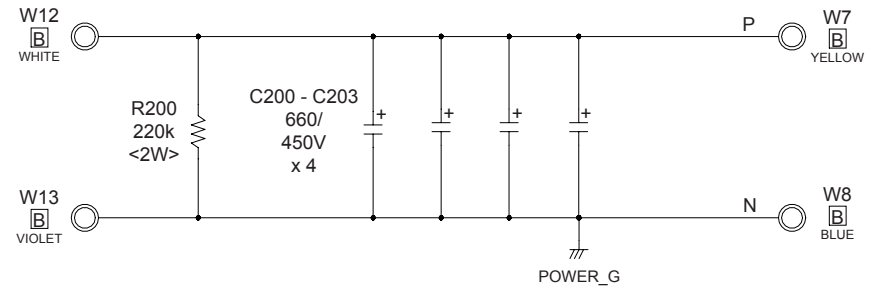

OUTDOOR UNIT
INDICATOR PCB
K10BC-1000YUE-D0

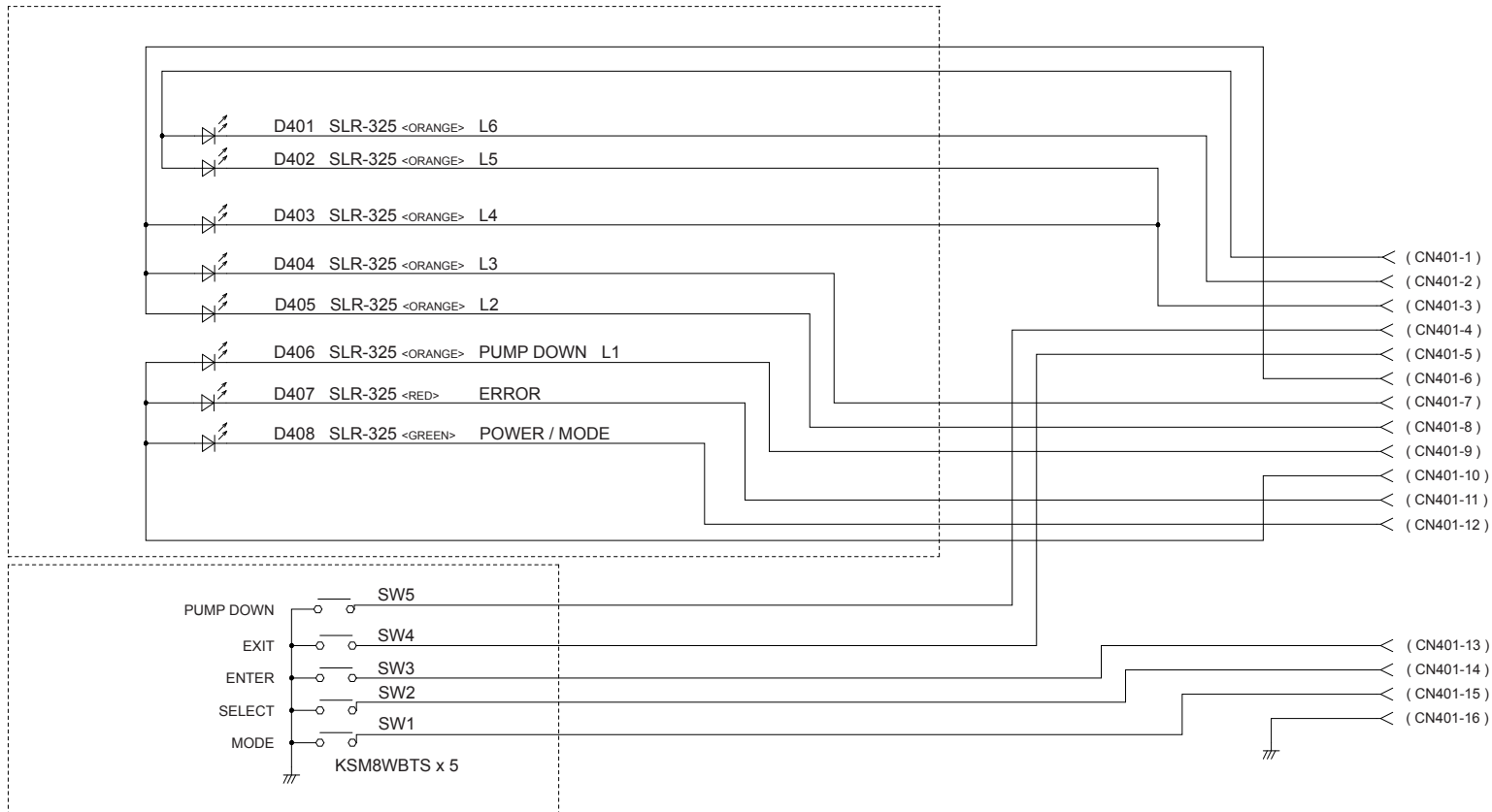

ERROR DETECTION

INDOOR UNIT and WIRED REMOTE CONTROL

If you use a wireless remote control, the lamp on the photo detector unit will output error codes by way of blinking patterns.

If you use a wired type remote control, error codes will appear on the remote control display. See the lamp blinking patterns and error codes in the table. An error display is displayed only during running.

Remote control

This is possible only on a wired remote control. If an error occurs, the following display will be shown. ("Er" will appear in the set room temperature display.)

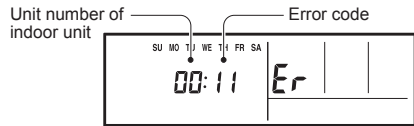

EX. Self-diagnosis

Receiver unit (option)

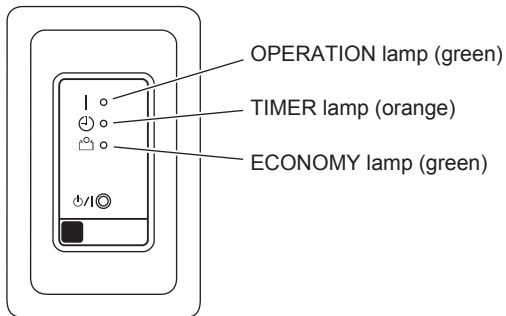

- : 0.5s on / 0.5s off
- ◇ : 0.1s on / 0.1s off
- () : Number of flashing

Receiver unit			Wired remote control	Description
OPERATION lamp (green)	TIMER lamp (orange)	ECONOMY lamp (green)		
● (1)	● (1)	◇	11	Serial communication error
● (1)	● (2)	◇	12	Wired remote control communication error
● (1)	● (5)	◇	15	Check run unfinished
● (2)	● (1)	◇	21	Unit number or Refrigerant circuit address setting error [Simultaneous Multi]
● (2)	● (2)	◇	22	Indoor unit capacity error
● (2)	● (3)	◇	23	Combination error
● (2)	● (4)	◇	24	• Connection unit number error (indoor slave unit) [Simultaneous Multi] • Connection unit number error (indoor unit or branch unit) [Flexible Multi]
● (2)	● (7)	◇	27	Master unit, slave unit set-up error [Simultaneous Multi]
● (3)	● (1)	◇	31	Power supply interruption error
● (3)	● (2)	◇	32	Indoor unit PCB model information error
● (3)	● (5)	◇	35	Manual auto switch error
● (4)	● (1)	◇	41	room temp. sensor error
● (4)	● (2)	◇	42	Indoor unit Heat Ex. Middle temp. sensor error
● (5)	● (1)	◇	51	Indoor unit fan motor error
● (5)	● (3)	◇	53	Drain pump error
● (5)	● (7)	◇	57	Damper error
● (5)	● (15)	◇	5U	Indoor unit error
● (6)	● (2)	◇	62	Outdoor unit main PCB model information error or communication error
● (6)	● (3)	◇	63	Inverter error
● (6)	● (4)	◇	64	Active filter error, PFC circuit error
● (6)	● (5)	◇	65	Trip terminal L error
● (6)	● (10)	◇	6A	Display PCB microcomputers communication error

Receiver unit			Wired remote control	Description
OPERATION lamp (green)	TIMER lamp (orange)	ECONOMY lamp (green)		
● (7)	● (1)	◇	71	Discharge temp. sensor error
● (7)	● (2)	◇	72	Compressor temp. sensor error
● (7)	● (3)	◇	73	Outdoor unit Heat Ex. liquid temp. sensor error
● (7)	● (4)	◇	74	Outdoor temp. sensor error
● (7)	● (5)	◇	75	Suction Gas temp. sensor error
● (7)	● (6)	◇	76	• 2-way valve temp. sensor error • 3-way valve temp. sensor error
● (7)	● (7)	◇	77	Heat sink temp. sensor error
● (8)	● (2)	◇	82	• Sub-cool Heat Ex. gas inlet temp. sensor error • Sub-cool Heat Ex. gas outlet temp. sensor error
● (8)	● (3)	◇	83	Liquid pipe temp. sensor error
● (8)	● (4)	◇	84	Current sensor error
● (8)	● (6)	◇	86	• Discharge pressure sensor error • Suction pressure sensor error • High pressure switch error
● (9)	● (4)	◇	94	Trip detection
● (9)	● (5)	◇	95	Compressor rotor position detection error (permanent stop)
● (9)	● (7)	◇	97	Outdoor unit fan motor 1 error
● (9)	● (8)	◇	98	Outdoor unit fan motor 2 error
● (9)	● (9)	◇	99	4-way valve error
● (9)	● (10)	◇	9A	Coil (expansion valve) error
● (10)	● (1)	◇	A1	Discharge temp. error
● (10)	● (3)	◇	A3	Compressor temp. error
● (10)	● (4)	◇	A4	High pressure error
● (10)	● (5)	◇	A5	Low pressure error
● (13)	● (2)	◇	J2	Branch boxes error [Flexible Multi]

OUTDOOR UNIT Indicator PCB

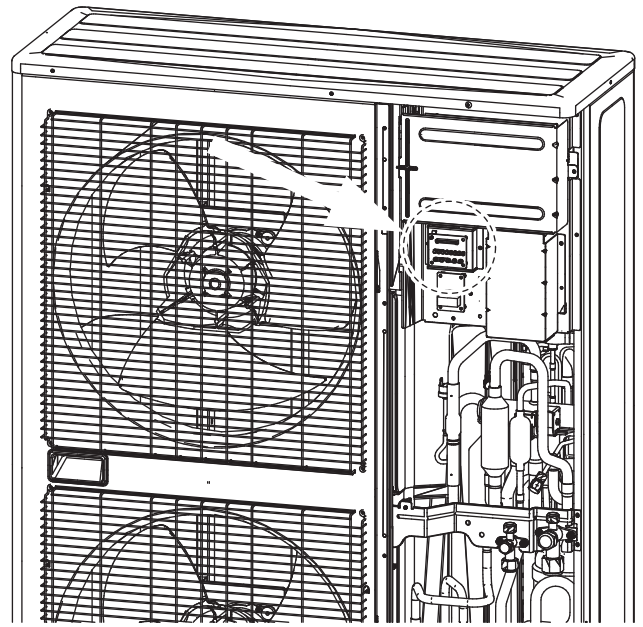
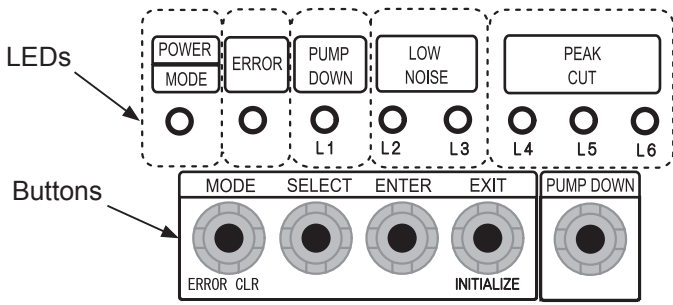

ERROR DETECTION

Display when an error occurs.

POWER MODE	ERROR	PUMP DOWN (L1)	LOW NOISE (L2) (L3)			PEAK CUT (L4) (L5) (L6)		
On	Blink (Hi speed)	Off	Off	Off	Off	Off	Off	Off

Check that the “ERROR” LED blinks, then press the [Enter] button once.

For details, refer to the following table.

DESCRIPTION	REMARK	LED display								
		POWER MODE	ERROR	PUMP DOWN (L1)	LOW NOISE (L2) (L3)		PEAK CUT (L4) (L5) (L6)			
Serial communication error	Serial forward transmission error immediately after operation	Blink (2 times)	On	Blink (1 time)	Blink (1 time)	Off	Off	On	On	On
	Serial forward transmission error during operation	Blink (2 times)	On	Blink (1 time)	Blink (1 time)	Off	On	Off	Off	Off
Indoor unit capacity error	Indoor unit capacity error	Blink (2 times)	On	Blink (2 times)	Blink (2 times)	Off	Off	Off	Off	On
Indoor unit error	Indoor unit error	Blink (2 times)	On	Blink (5 times)	Blink (15 times)	Off	Off	Off	Off	On
Outdoor unit main PCB error	Outdoor unit PCB model information error	Blink (2 times)	On	Blink (6 times)	Blink (2 times)	Off	Off	Off	Off	On
Inverter PCB error	Inverter error	Blink (2 times)	On	Blink (6 times)	Blink (3 times)	Off	Off	Off	Off	On
IPM error	Trip terminal L error	Blink (2 times)	On	Blink (6 times)	Blink (5 times)	Off	Off	On	On	On
Discharge temp. sensor error	Discharge temp. sensor 1 error	Blink (2 times)	On	Blink (7 times)	Blink (1 time)	Off	Off	Off	Off	On
Compressor temp. sensor error	Compressor temp. sensor 1 error	Blink (2 times)	On	Blink (7 times)	Blink (2 times)	Off	Off	Off	Off	On
Outdoor unit Heat Ex. sensor error	Heat Ex. centre temp. sensor error	Blink (2 times)	On	Blink (7 times)	Blink (3 times)	Off	Off	On	Off	Off
	Outdoor unit Heat Ex. liquid temp. sensor error	Blink (2 times)	On	Blink (7 times)	Blink (3 times)	Off	Off	On	On	On
Outdoor temp. sensor error	Outdoor temp. sensor error	Blink (2 times)	On	Blink (7 times)	Blink (4 times)	Off	Off	Off	Off	On
Heat sink temp. sensor error	Heat sink temp. sensor error	Blink (2 times)	On	Blink (7 times)	Blink (7 times)	Off	Off	Off	Off	On
Current sensor error	Current sensor 1 error (stoppage permanently)	Blink (2 times)	On	Blink (8 times)	Blink (4 times)	Off	Off	Off	Off	On
Pressure sensor error	High pressure switch 1 error	Blink (2 times)	On	Blink (8 times)	Blink (6 times)	Off	On	Off	Off	Off
	Pressure sensor error	Blink (2 times)	On	Blink (8 times)	Blink (6 times)	Off	On	On	On	Off
Trip detection	Trip detection	Blink (2 times)	On	Blink (9 times)	Blink (4 times)	Off	Off	Off	Off	On
Compressor motor control error	Rotor position detection error (stoppage permanently)	Blink (2 times)	On	Blink (9 times)	Blink (5 times)	Off	Off	Off	Off	On
Outdoor unit fan motor 1 error	Duty abnormal	Blink (2 times)	On	Blink (9 times)	Blink (7 times)	Off	Off	On	On	On
Outdoor unit fan motor 2 error	Duty abnormal	Blink (2 times)	On	Blink (9 times)	Blink (8 times)	Off	Off	On	On	On
4-way valve error	4-way valve error	Blink (2 times)	On	Blink (9 times)	Blink (9 times)	Off	Off	Off	Off	On
Discharge temp. 1 error	Discharge temp. 1 error	Blink (2 times)	On	Blink (10 times)	Blink (1 time)	Off	Off	Off	Off	On
Compressor temp. error	Compressor 1 temp. error	Blink (2 times)	On	Blink (10 times)	Blink (3 times)	Off	Off	Off	Off	On
Pressure error 2	Low pressure error	Blink (2 times)	On	Blink (10 times)	Blink (5 times)	Off	Off	Off	Off	On

OUTDOOR UNIT TEST RUN

Before the test run, refer to the figure and check the following items.

<input type="checkbox"/>	Is the outdoor unit securely installed?
<input type="checkbox"/>	Have you performed gas leakage inspection? (Connection joints of various pipes (flang connection, brazing))
<input type="checkbox"/>	Is the heat insulation done completely? (Gas pipe, liquid pipe, drain hose extension on indoor unit side etc)
<input type="checkbox"/>	Is the water discharging from drain without any problems?
<input type="checkbox"/>	Are the cables connected correctly?
<input type="checkbox"/>	Are the cables as per specifications?
<input type="checkbox"/>	Is the earth wire connected accurately?
<input type="checkbox"/>	Are there any obstacles blocking the suction gate, and outlet of the indoor/outdoor units?
<input type="checkbox"/>	Have you filled the specified amount of refrigerant?
<input type="checkbox"/>	Are the stop valves of gas pipe and liquid pipe fully open?
<input type="checkbox"/>	Has the power been supplied to crankcase heater for more than 6 hours?

If there are problems, adjust immediately and recheck.

Test run method

Be sure to configure test run settings only when the outdoor unit has stopped operating.

Depending on the communication status between the indoor and outdoor units, it may take several minutes for the system to start operating after settings for the test run are complete.

After the test run settings are complete, the outdoor units and the connected indoor units will start operating. Room temperature control will not activate during test operation (continuous operation).

If a knocking sound can be heard in the liquid compression of the compressor, stop the unit immediately and then energize the crank case heater for a sufficient length of time before restarting the operation.

Test run setting method (it can be performed in the following two ways)

Set with test run setting (refer to installation instructions manual of indoor unit for further details) available in the remote control.

Cooling Operation" and Heating Operation" can be set using , SELECT button and ENTER button available on the board of display unit.

(*Make sure to perform the first test run with cooling operation.)

Set as per the procedure given below.

Check items during test run

<input type="checkbox"/>	Is the outdoor unit making any abnormal noise or vibrating significantly?
<input type="checkbox"/>	Is the cold air or hot air blowing from indoor unit according to the operation mode?
<input type="checkbox"/>	Check that the "ERROR" LED blinks If it has displayed, check the error content as per 12.2. described later.
<input type="checkbox"/>	Operate the unit according to the operating manual provided with the indoor unit, and check that it is operating normally.

Setting method

- (1) Turn on the power of the outdoor unit and enter standby mode.

POWER	ERROR	PUMP DOWN	LOW NOISE			PEAK CUT	
MODE		(L1)	(L2)	(L3)	(L4)	(L5)	(L6)
On	Off	Off	Off	Off	Off	Off	Off

- (2) Press the ENTER button for more than 3 seconds.

POWER	ERROR	PUMP DOWN	LOW NOISE			PEAK CUT	
MODE		(L1)	(L2)	(L3)	(L4)	(L5)	(L6)
Blink	Off	Off	Off	Blink	Off	Off	Off

- (3) Press the SELECT button,
LED of the test run mode Switched between "COOL" and "HEAT".

Cooling test mode

POWER	ERROR	PUMP DOWN	LOW NOISE			PEAK CUT	
MODE		(L1)	(L2)	(L3)	(L4)	(L5)	(L6)
Blink	Off	Off	Off	Blink	Off	Off	Off

Heating test mode

POWER	ERROR	PUMP DOWN	LOW NOISE			PEAK CUT	
MODE		(L1)	(L2)	(L3)	(L4)	(L5)	(L6)
Blink	Off	Off	Blink	Off	Off	Off	Off

- (4) After confirm the operation mode, Press ENTER button.
The display changes as follows, and Air conditioner starts operation.

Cooling test mode

POWER	ERROR	PUMP DOWN	LOW NOISE			PEAK CUT	
MODE		(L1)	(L2)	(L3)	(L4)	(L5)	(L6)
Blink	Off	Off	Off	On	Off	Off	Off

Heating test mode

POWER	ERROR	PUMP DOWN	LOW NOISE			PEAK CUT	
MODE		(L1)	(L2)	(L3)	(L4)	(L5)	(L6)
Blink	Off	Off	On	Off	Off	Off	Off

- (5) Press [ENTER] button.
Air conditioner stopped operation.

POWER	ERROR	PUMP DOWN	LOW NOISE			PEAK CUT	
MODE		(L1)	(L2)	(L3)	(L4)	(L5)	(L6)
On	Off	Off	Off	Off	Off	Off	Off

OUTDOOR UNIT PUMP DOWN

⚠ WARNING

Never touch electrical components such as the terminal blocks except the button on the display board. It may cause a serious accident such as electric shock.

During the pump-down operation, make sure that the compressor is turned off before you remove the refrigerant piping.

Do not remove the connection pipe while the compressor is in operation with 2-way or 3-way valve open. This may cause abnormal pressure in the refrigeration cycle that leads to breakage and even injury.

⚠ CAUTION

Perform the pump down operation before disconnecting any refrigerant pipe or electric cable.

Collect refrigerant from the service port or the 3-way valve if pump down cannot be performed.

In case of a group control system installation, do not turn the power off pump down is completed in all outdoor units.
(Group control system installation described in SPECIAL INSTALLATION METHODS" in the installation manual of the indoor unit.)

- Operate [PUMPDOWN] button on the display board in the manner described below.

Preparation for pump down
Confirm that the power is off,
and then open the service panel.

Procedure

- Check the 3-way valves (both the liquid side and gas side) are opened.
- Turn the power on.

POWER	ERROR	PUMP DOWN	LOW NOISE			PEAK CUT	
MODE		(L1)	(L2)	(L3)	(L4)	(L5)	(L6)
On	Off	Off	Off	Off	Off	Off	Off

- Press [PUMP DOWN] button for 3 seconds or more after 3 minutes after power on.

POWER	ERROR	PUMP DOWN	LOW NOISE			PEAK CUT	
MODE		(L1)	(L2)	(L3)	(L4)	(L5)	(L6)
On	Off	On	Off	Off	On	On	On

LED display lights on as shown in the above figure and the fans and the compressor start operating.

- If the [PUMP DOWN] button is pressed while the compressor is operating, the compressor will stop, then start again in about 3 minutes.

- LED display will change as shown below about 3 minutes after the compressor starts. Fully close the 3-way valve on the liquid pipe side at this stage.

POWER	ERROR	PUMP DOWN	LOW NOISE			PEAK CUT	
MODE		(L1)	(L2)	(L3)	(L4)	(L5)	(L6)
On	Off	On	Off	Off	Off	On	On

- If the valve on the liquid pipe side is not closed, the pump down cannot be performed.

- When LED display changes as shown in the below figure close the 3-way valve on the gas pipe side tightly.

POWER	ERROR	PUMP DOWN	LOW NOISE			PEAK CUT	
MODE		(L1)	(L2)	(L3)	(L4)	(L5)	(L6)
On	Off	On	Off	Off	Off	Off	On

- if the valve on the gas pipe side is not closed, refrigerant may flow into the piping after the compressor stops.

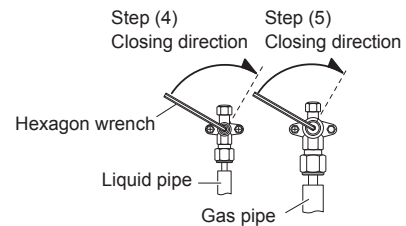

- LED display changes after 1 minute as shown in the figure below.

POWER	ERROR	PUMP DOWN	LOW NOISE			PEAK CUT	
MODE		(L1)	(L2)	(L3)	(L4)	(L5)	(L6)
On	Off	On	Off	Off	Off	Off	Off

Fans and compressor stop automatically.

- If the pump down is successfully completed (the above LED display is shown), the outdoor unit remains stopped until the power is turned off.

- Turn the power off.

POWER	ERROR	PUMP DOWN	LOW NOISE			PEAK CUT	
MODE		(L1)	(L2)	(L3)	(L4)	(L5)	(L6)
Off	Off	Off	Off	Off	Off	Off	Off

PUMP DOWN is completed.

(Note)

- To stop pump down, press the [PUMP DOWN] button again.
- To start the pump down again after the compressor is automatically stopped due to an error, turn the power off and open the 3-way valves. Wait 3 minutes, turn the power on and start the pump down again.
- When starting the operation after completion of the pump down, turn the power off, and then open the 3-way valves. Wait 3 minutes, turn the power on and perform a test run in the "COOL" operation mode.
- If an error occurs, recover the refrigerant from service port.

PARTS

INDOOR UNIT

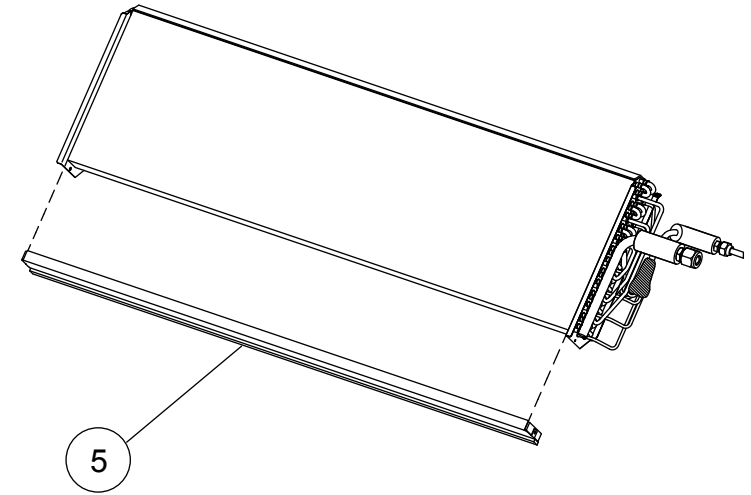
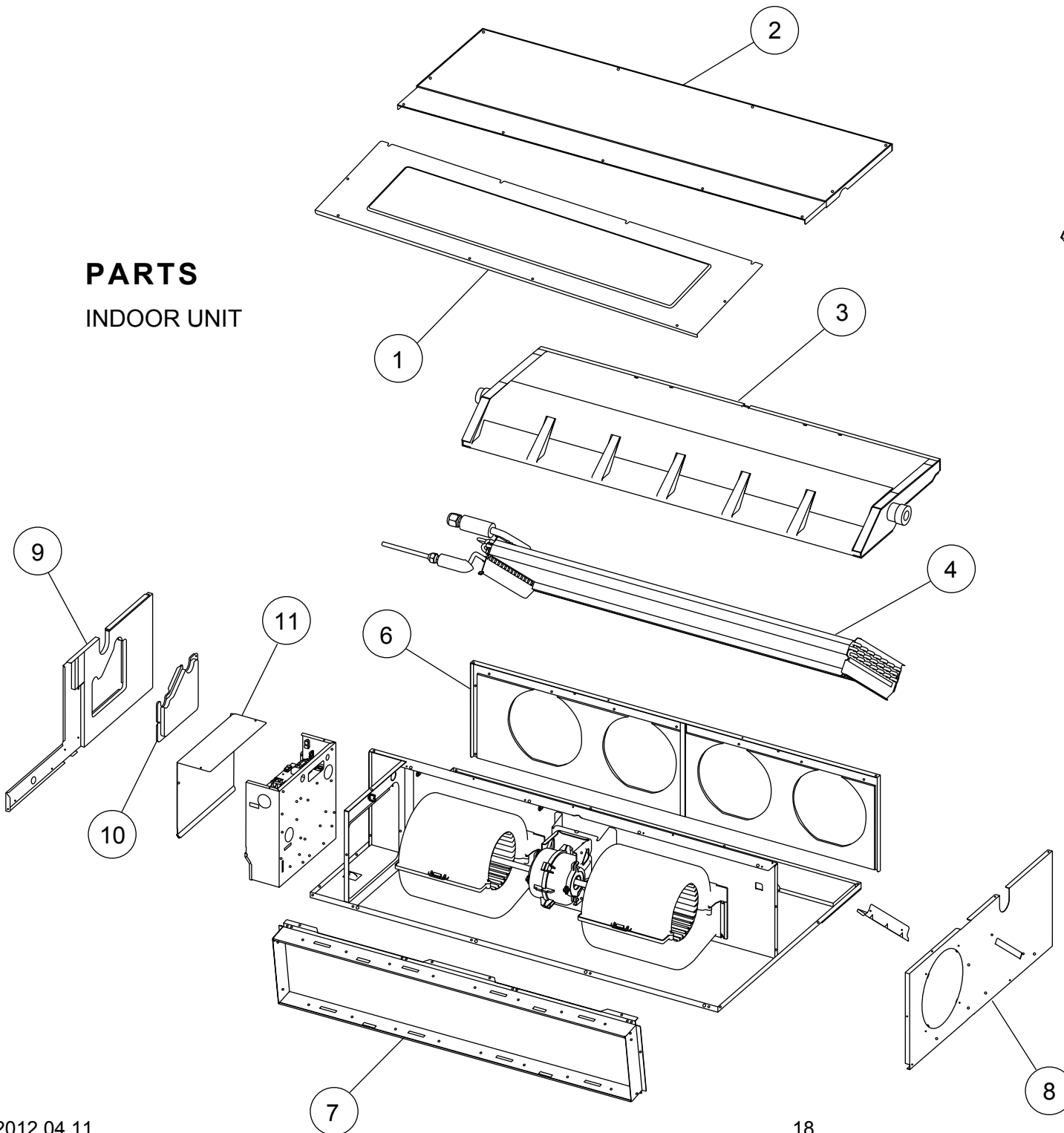

Ref.	Description	Part number
1	Intake Cover Sub Assy	9374512010
2	Main Panel Sub Assy	9374511013
3	Drain Pan Sub Assy	9374513017
4	Evaporator Total Assy	9374517251
5	Seal Panel Sub Assy	9374515011
6	Outlet Panel Sub Assy	9374510016
7	Intake Frame Assy	9374216017
8	Cabinet L Sub Assy	9374509010
9	Cabinet R Sub Assy	9374508020
10	Bracket Pipe Sub Assy	9374514014
11	Control Cover A Sub Assy	9374516025

INDOOR UNIT

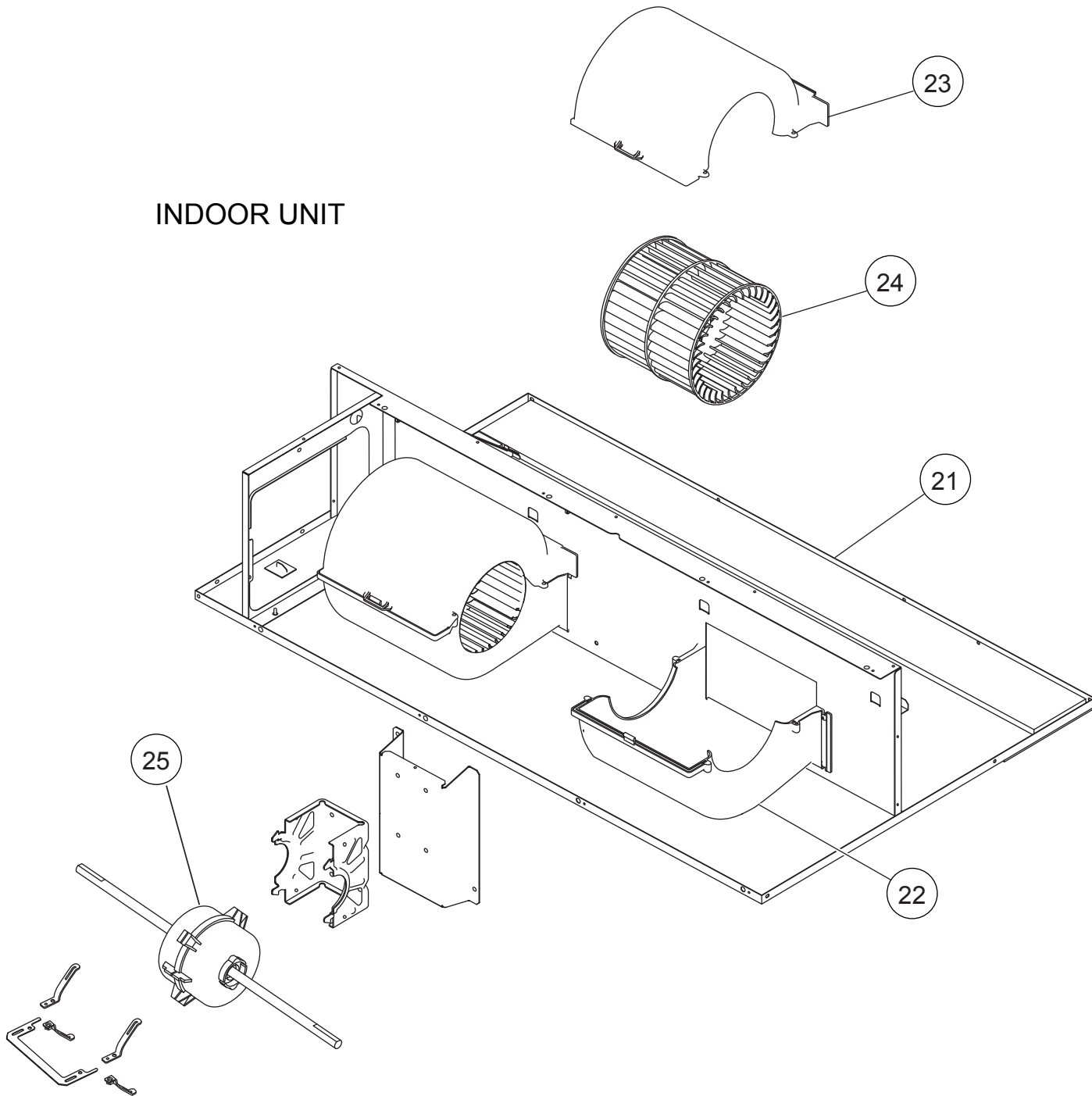

Ref.	Description	Part number
21	Base Sub Assy	9374504015
22	Casing A	9374233014
23	Casing B	9374234011
24	Sirocco Fan Assy	9356531046
25	Fan Motor	9603213015
--	Panel (Control Box)	9374210015

INDOOR UNIT
Control unit

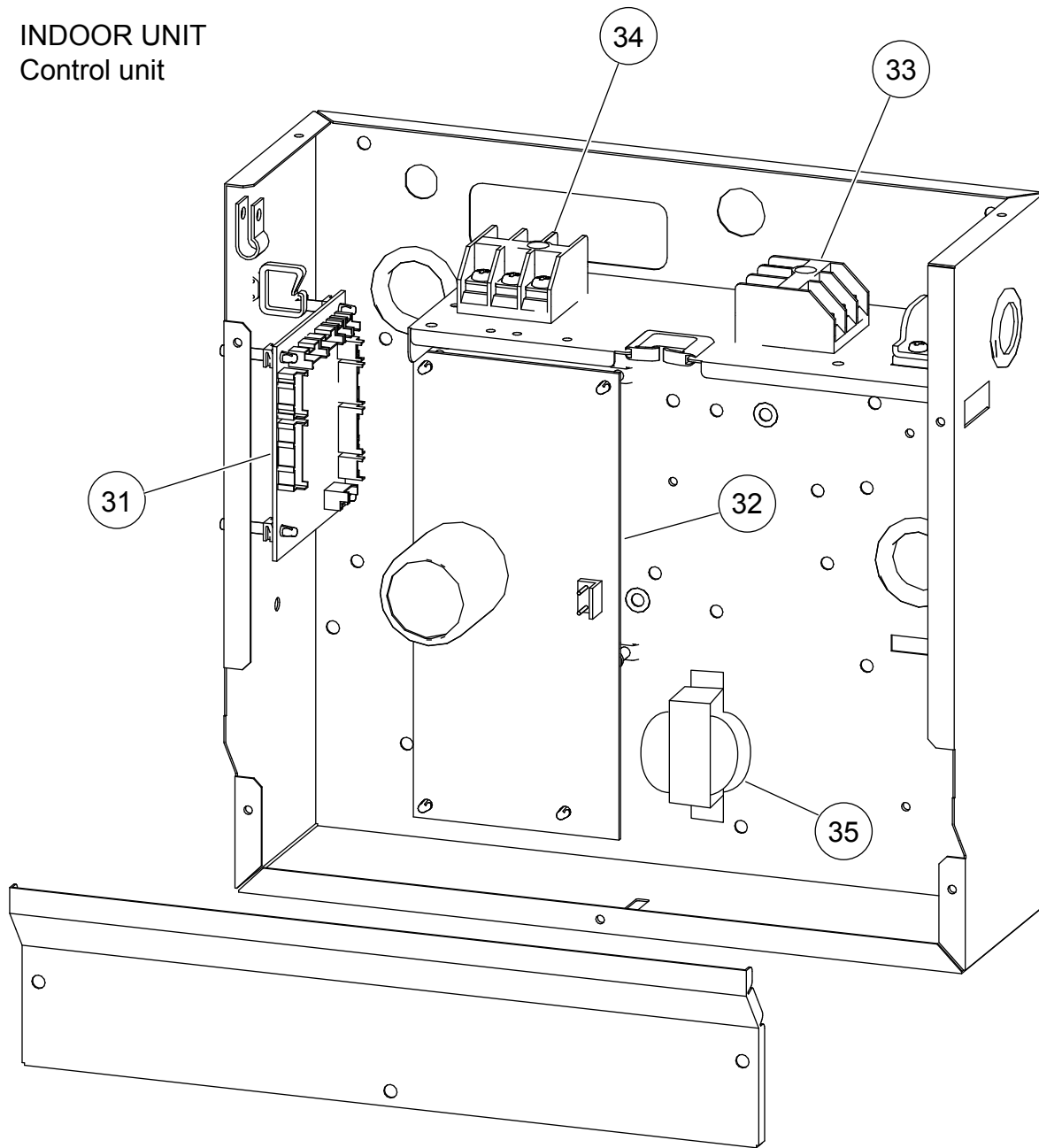

Ref.	Description	Part number
31	Main PCB	9709245040
32	Power Supply PCB	9707398359
33	Terminal 3P	9703345012
34	Terminal 3P	9306489045
35	Reactor Assy	9707457018
36	Remote Control	9318593013
--	Room Thermistor	9703299025
--	Pipe Thermistor	9703297021

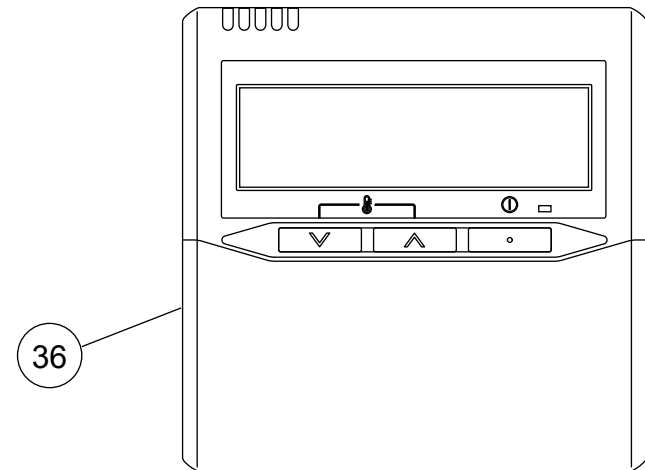

PARTS

OUTDOOR UNIT

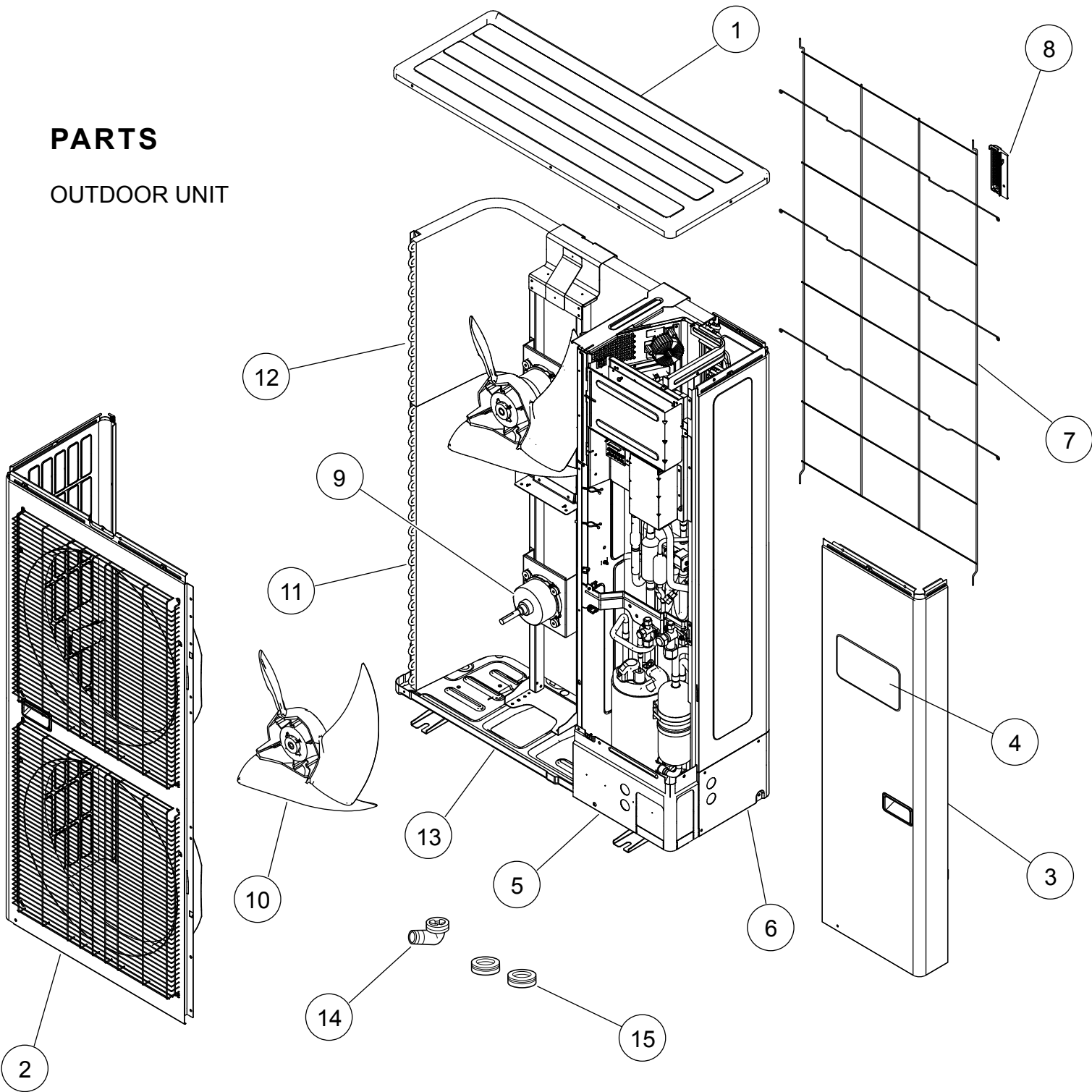

Ref.	Description	Parts number
1	Top Panel Sub Assy	9374417056
2	Front Panel Sub Assy	9374414109
3	Sevice Panel Sub Assy	9374415090
4	Emblem Rear	9351355005
5	Pipe Cover Front	9378861015
6	Right Panel Sub Assy	9374416189
7	Protective Net	9375381042
8	Thermo Holder	9375211011

Ref.	Description	Parts number
9	Motor DC Brushless	9602843039
10	Propeller Fan Assy	9366378020
11	Condenser A Sub Assy	9374420261
12	Condenser B Sub Assy	9374422081
13	Base Assy	9374166220
14	Drain Assy	9303029015
15	Drain Cap	313166024302

OUTDOOR UNIT
Control box

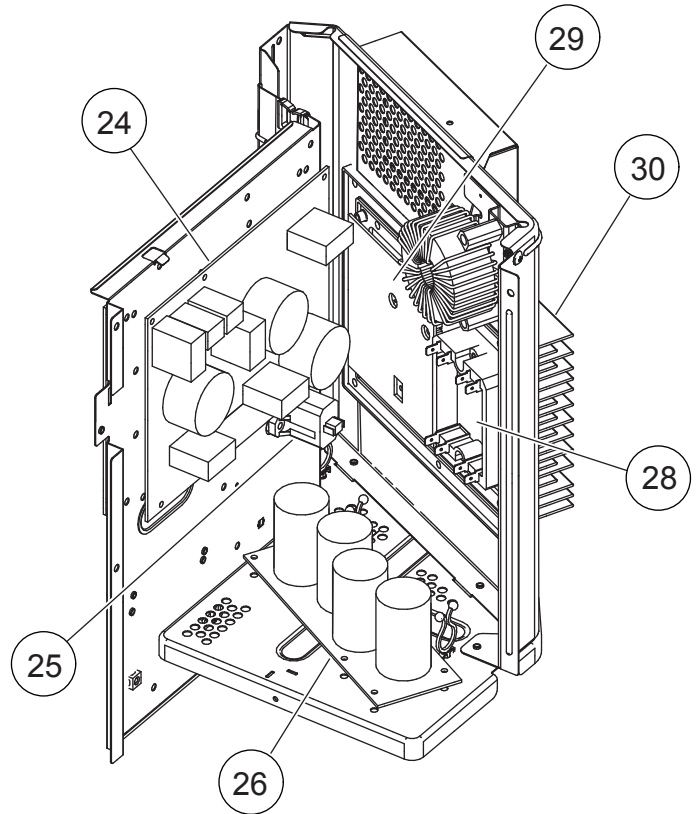
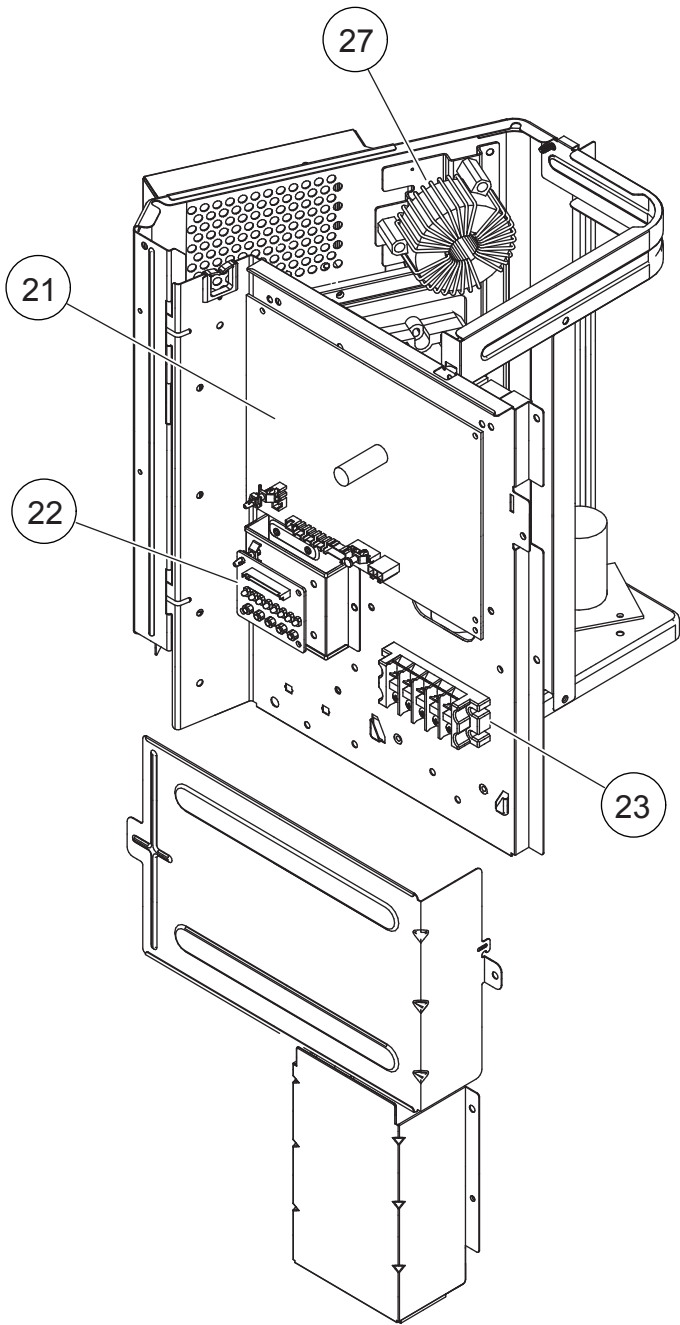

Ref.	Description	Parts number
21	Main PCB	9708690148
22	Indicator PCB	9708678016
23	Terminal	9900203023
24	Filter PCB	9708688015
25	Thermistor	9704265012
26	Capacitor PCB	9707257083
27	Choke Coil	9900624019
28	ACTPM	9707592016
29	Transistor PCB	9708647043
30	Heat Sink	9380358008
--	Outdoor Thermistor	9900210069
--	Thermistor Assy (CN63)	9900599027
--	Thermistor Assy (CN62)	9900598013

OUTDOOR UNIT

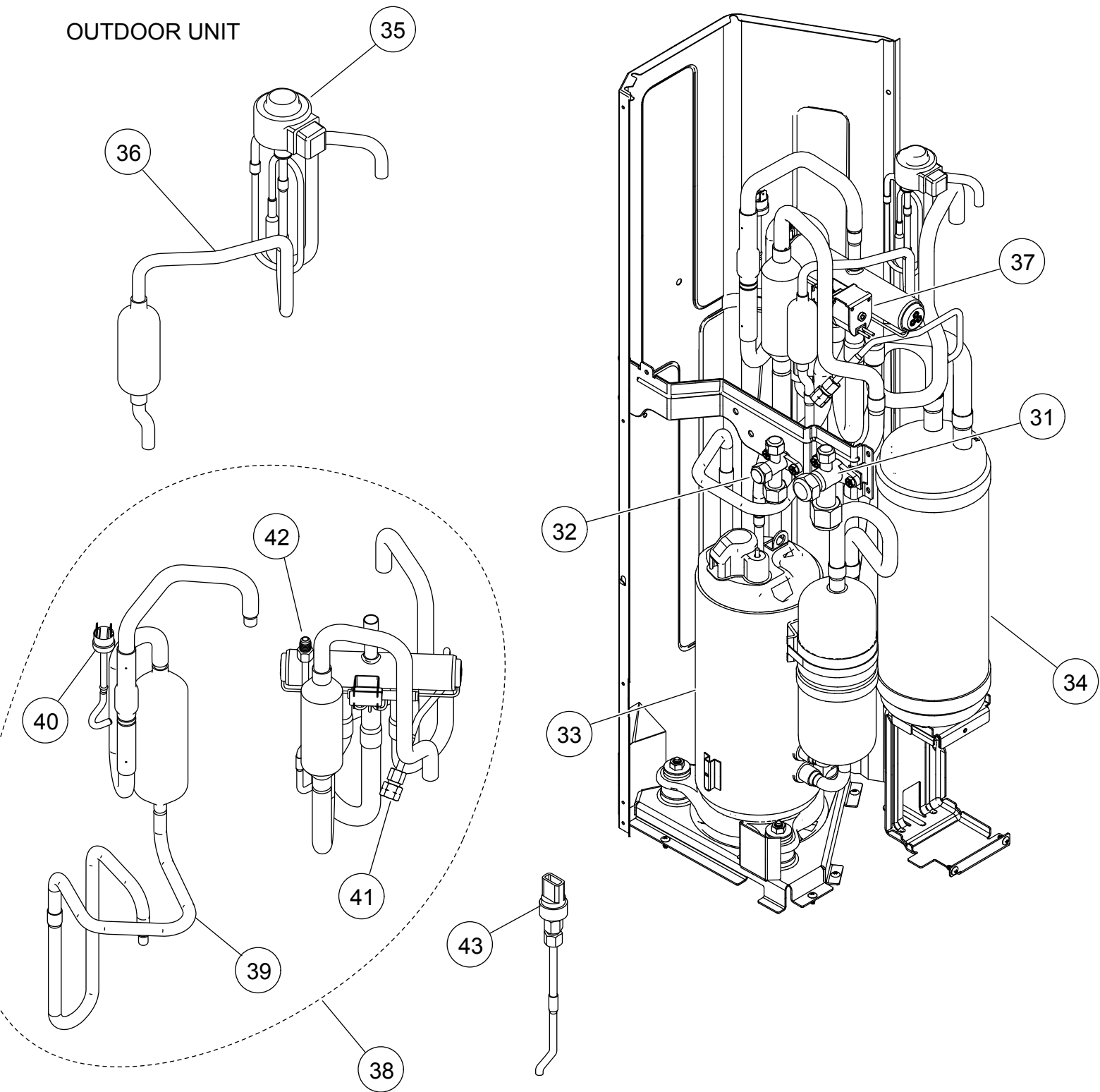







Ref.	Description	Parts number
31	3-way Valve Assy	9379079006
32	3-way Valve Assy	9379077002
33	Compressor	9810153005
34	Accumulator	9379014021
35	Expansion Valve Coil	9970096044
36	Expansion Valve Assy	9370947243
37	Solenoid	9970055072



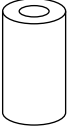

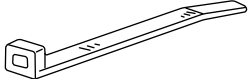
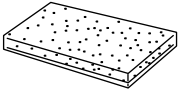
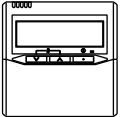
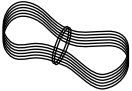
Ref.	Description	Parts number
38	4-way Valve Assy	9374425235
39	Discharge Pipe Assy	9371581248
40	Pressure Switch	9900186012
41	Check Joint Assy	9372802038
42	Union joint Assy	9379068000
43	Sensor	9900505080

ACCESSORIES

INDOOR UNIT

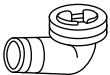
Name and Shape	Q'ty	Application	Part number
Hanger 	4	For suspending the indoor unit from ceiling	9356563009
Special nut A (large flange) 	4		313005446653
Special nut B (small flange) 	4		313005446759
Coupler heat insulation (large) 	1	For indoor side pipe joint (gas pipe)	9378173569
Coupler heat insulation (small) 	1	For indoor side pipe joint (liquid pipe)	9378173521
Cable tie 	(large) 1	For fixing the drain hose	312300787605
	(small) 1	Fixing the remote cord	313361275805
Drain hose insulation 	1	Insulates the drain hose and vinyl hose	313806217708
Remote control 	1	For air conditioner operation	9318593013
Remote control cord 	1	For connecting the remote control	9372714010
Tapping screw (ø4 × 16) 	2	For installing the remote control	0700181108

OUTDOOR UNIT

Name and Shape	Q'ty	Application	Part number
Drain pipe 	1	For drain piping work	9303029015
Drain cap 	2		313166024302
Binder 	3	For binding power supply cable and connection cable	9374688012
One-touch bush 	2	For power supply cable and connection cable installation	9378779013

OPTIONAL PARTS

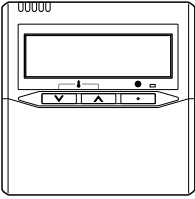
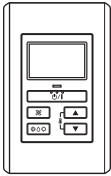
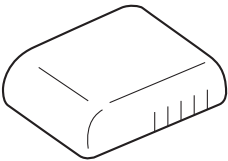
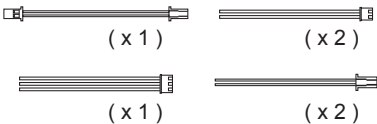
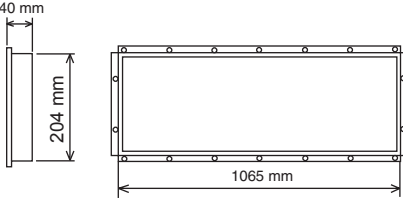
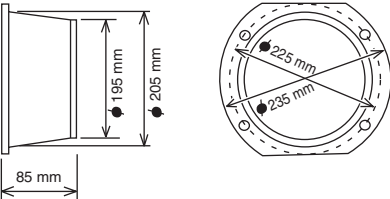
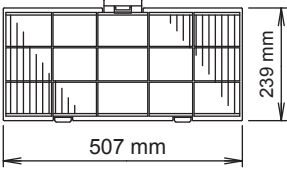
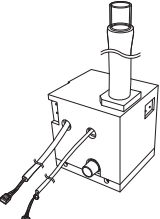
Parts name and model name	Application
Wired remote control UTY-RNNYM 	For air conditioner operation
Simple remote control UTY-RSNYM 	For air conditioner operation
Remote sensor unit UTY-XSZX 	Room temperature sensor
External connect kit UTD-ECS5A 	For control input/output port
Square flange UTD-SF045T 	
Round flange UTD-RF204 	
Long-life filter UTD-LF25NA 	
Drain pump unit UTZ-PX1NBA 	

1301G4159